

news

IDEAS CLUB (BENDIGO)

inVent Newsletter



The Inventors Association of Australia (Victoria) 30 Reids Lane Warranwood Vic 3134
HOTLINE: Ph 0421 767 790 . Web: www.inventorvic.com.au Email: mandrgroup@sandarra.net.au

NEXT MEETING

Wed 7th December 2011
6.30 pm
47 Miller Crescent
Mount Waverley

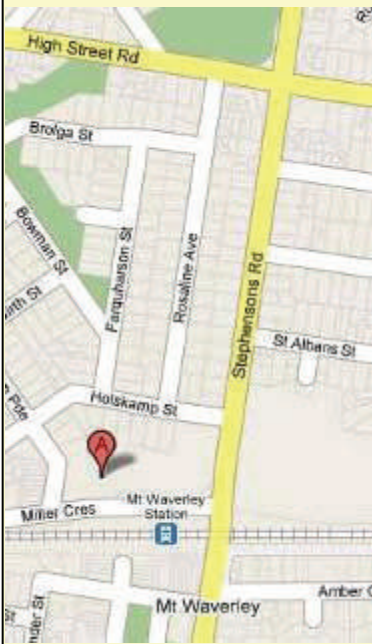

IAA Members Award
Presented
By
Gary Hegedus
IAA Vic Sponsor

IAA VIC MEMBERS AWARDS

Chinese delegation of 18 visits with the IAA Vic

From the President

This month, the IAA Vic received an email from Susan Jiang who works with Australian Technical Experts Network (ATEN), housed in the university of Canberra and Beijing.

The organization's main function is to coordinate visiting activities for any Chinese delegations visiting Australia. Susan wrote to the IAA Vic advising there was a Chinese delegation of 18, from Suzhou Intermediate People Court who had a strong desire to attain some knowledge about Legal protection for Innovative Economy, with special focus on intellectual property protection and contract management. The delegation was visiting Melbourne on the 21st October 2011. Susan was directed to us through IP Australia.

We were able to assist them with their request and immediately contacted Stephen Anderson, one of our Patent Attorneys on our yearly roster. The IAA Vic hosted the function at the function room at Club Ringwood. President Debbie Dash and Treasurer Ron Porteous represented the IAA Vic on their behalf. Stephen expertly put together a power point presentation and with the help of their interpreter, Michael; Stephen was able to deliver the requested information within the requested two hour time frame. We took a group photo of the event as a momentum. For more detailed information of ATEN, please the website at www.aica.com.cn/eng/



Virginia Beniac-Brooks | Arcadia IP
1 Campbell St. Kew 3101 Vic
T: (03) 9817 7794
E: enquiry@arcadialawyers.com.au



Virginia is regularly on our IPTA Patent Attorney roster and one of many that gives of their time and expertise to the

benefit of the members of the IAA Vic and visitors. On behalf of the committee and members, we would like to thank her for her commitment and support given to the IAA Vic over the years. Virginia has had over 20 years experience in the IP field including trademarks, design rights, copyright and related litigation. Virginia's practice primarily conducts and assists in patent matters before the Australian, New Zealand, European Patent Offices and the Australian Federal Court. Virginia works in a range of other areas including property, wills, administration of estates, litigation and intellectual property matters. **Thank you Virginia** for your informative presentation.

Len Williams is a member of the Bendigo Ideas Club as well as the Regional Victoria representative on the IAA Vic committee. Len was a finalist in the recent Bendigo Inventor Awards 2011 and entered the IAA Vic Member Competition this month. Unfortunately, Debbie Dash was unable to attend the meeting so she was unable to present her invention this month. Salvatore Spataro was also advertised and was unable to attend the meeting. We look forward to the February meeting for these two inventions/innovations, kicking off the competition for 2012.

Len described instances he has experienced whilst camping 'under the stars'. 'It's o.k. to go to your tent at night and the weather is beautiful, but to wake up to flash flooding and mud everywhere is terrible!' The idea to invent a way for 4 wheel drives to get out of a bogged situation was a must as far as Len was concerned. Len gave a detailed description of his very clever idea by drawing a wheel of a paddle steamer on the white board and demonstrated how the concept worked using a power point presentation. A major problem that Len faced when designing, was how to attach this light weight product to the wheels when the wheels were up to their 'eyeballs' in mud! Like all successful inventors, he overcame the obstacles and succeeded in his quest. Len has invented a 'Solution to vehicle recovery and extraction from a bogged situation' for 4 wheel drives. **Well done Len.** Please contact Len on (03) 5439 5206 or email gyrolen@tpg.com.au for any more information on his invention.

Rosa Nathan was the rose between the thorns this month in the competition. Rosa also entered the Bendigo Inventor Awards this year. Rosa has 3 inventions that she took to the Awards. Rosa has a passion for making life easier and healthier and her inventions testify as such.

1. Doggy P.. Pickup' containment. No-one likes doing this, especially on rainy nights and Rosa has observed on her walks, and in her market research, that people with wheel chairs or walking sticks have difficulty in this p.. pickup activity. This invention makes doggy independent by wearing her cleverly designed product and a perfect doggy product for the challenged dog walker.

2. A muesli health bar that doesn't have any added fat, has no preservatives, no dairy, egg, or wheat. This health bar would be suitable for schools, hospitals, nursing homes, travel and even be a nourishing 3rd world food bar.

3. This perfectly packed travel bag has numerous clear plastic boxes that fit into the trolley suitcase. Items that are packed in these boxes, could contain shoes, sandals, thongs into one size box and then other sizes, are filled with everything one needs for a holiday. An underwear box, a dress box, cosmetic box, cardigan/jumper box and so forth. The entire holiday wardrobe is packed in different sized clear plastic boxes, clothing being easily identifiable, neatly and vertically packed into the suitcase.

Well done Rosa! Catch up with Rosa at the Christmas Celebration Dinner for sales or other product details.

Peter McDonald has a very interesting invention. Peter is an avid home gardener and can trace his interest in gardening back to his youth. Peter explained that in 2004-2005, he thought that the biggest problem in the home garden was the flying pests of the air— Birds! They fly in and feed off the fruit and then other birds watch and basically come in and feed as well. Peter thought there was a need for something to 'hide' the fruit from the birds. He had tried hiding the fruit by 'netting' and that presented problems, how to get to the fruit easily for example. He started experimenting with different shapes of cardboard until he came up with the polystyrene cup which then needed something or other to hold it in place. Peter couldn't let go of the idea and gave his 'subconscious' time to further develop the idea. He started to think about clip designs and had a prototype of one made but found that it wasn't quite doing the job successfully. More time elapsed and he redesigned his clip and now has a winning clip! Peter calls his invention the 'Bird Busta Clip'. This clip holds a polystyrene cup in place over the fruit and is also clipped to the vine so as to keep the cup in place protecting the fruit from the birds. This clip is designed for domestic use and has proven to be most successful in protecting fruits such as passionfruit, apples, apricots, plums etc. Peter recently made a sale in the USA. Well done! For more information on Bird Busta Clips or sales, please contact Peter on (03) 9587 2266

IAA Vic Monthly Member Competition

Len Williams



Rosa Nathan

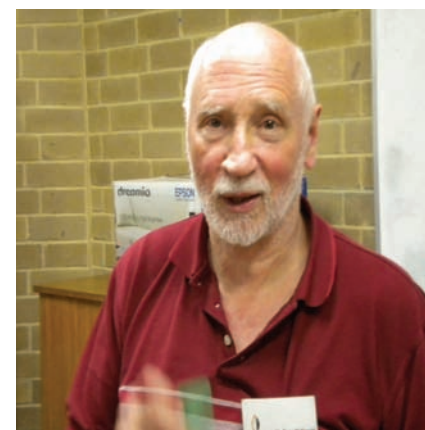

Peter Mc Donald



**THE IAA Vic PRESENTS
CHRISTMAS WITH A DIFFERENCE**

AT

**47 MILLER CRESCENT
MOUNT WAVERLEY**

ON

WEDNESDAY 7th DECEMBER

FROM

6:30 PM TO 10:00 PM

Come enjoy the rich experience

IN LAVISH STYLE

WITH

A SCRUMPTIOUS 2 course dinner

Served at 7:00 PM SHARP

COMPLEMENTARY

WINES,

SOFT DRINKS & SNACKS on each table

IAA Vic MEMBERS AWARDS

PRESENTED by Gary Hegedus

An evening of PRIZES & SURPRISES

NOT TO BE MISSED

ADULTS/CHILDREN (13-18) \$15

For bookings please contact

RAY: 0402 849 982

BOOKINGS ESSENTIAL

BLOOD OUT OF STONE IS POSSIBLE.



\$10,000

FREE FROM THE TAX DEPARTMENT

PRESENTED BY:

LEN WILLIAMS - GYROLEN@TPG.COM.AU

RESEARCH & DEVELOPMENT TAX OFFSET LOOPHOLE

If a company makes a Loss and has registered for R & D , it could receive a cash cheque of 37.5% of the loss, courtesy of the Australian Tax Office.

This is extremely unusual, it only applies to R & D Tax approved companies

RESEARCH & DEVELOPMENT TAX OFFSET IS VERY APPROPRIATE FOR IAA MEMBERS

1. You have a great Invention idea, but can't justify the time or cost.?
2. R & D is very suitable for semi-retired or under employed creative Inventors.
3. **Warning**, good bookwork and record keeping is required.

MANAGER OF R & D



You become the employee of your company as the
Manager of Research & Development

GETTING STARTED

1. Set up Company or Trust or a Partnership which owns your invention
2. Register with Innovation Australia
3. Possibly lodge a Provisional or Innovation Patent
4. Keep excellent records of invoices, receipts
5. Keep a detailed diary of events



REPORTS TO ATO

Quarterly

- Individual IAS return of manager salary
- Company IAS return showing PAYE, \$0 BAS

Annually

- Individual tax return
 - Company tax return
 - Company GST return
- 

EXPENSE CLAIMS

Workshop, tools, replacements, depreciation
▪ All that Bunning's stuff \$2500

Travel
▪ To IAA meetings, bank, advisors \$2000

Internet, phone \$1100

Home Workshop / Office expenses: \$1300

▪ Share of based on say floor size used.

▪ Power, light, heat

▪ Rates, water

▪ Interest on house loan

Total expenses before salary \$6900

*** Remember you most likely would have paid these costs anyway.**

**Manager's Salary paid to self, loaned back to Company,
no actual cash changes hands \$40000**

INVENTOR OBTAINS \$10,000 FROM ATO

Income	<u>\$ 0</u> - no sales in startup year
Les Expenses	\$ 6900 - workshop, office, travel, internet
Salary to manager	<u>\$40000</u> - tax payable \$5500
Total Loss	<u>\$46900</u>

R & D Tax offset 37.5% of costs	\$18800 -cheque from ATO
Less tax payable by manager	\$ 5500
Less Tax agents fees	\$ 2000
Less Worksafe Insurance for manager	<u>\$ 1300</u>
	<u>\$10000</u>

= Net cash benefit to Inventor \$10,000

BLOOD OUT OF STONE IS POSSIBLE.

\$10,000

FREE FROM THE TAX DEPARTMENT



PRESENTED BY: LEN WILLIAMS GYROLEN@TPG.COM.AU

LINKS: ATO

[HTTP://WWW.ATO.GOV.AU/CORPORATE/CONTENT.ASPX?
DOC=/CONTENT/34652.HTM](http://www.ato.gov.au/corporate/content.aspx?doc=/content/34652.htm)

INNOVATION AUST

[HTTP://WWW.AUSINDUSTRY.GOV.AU/INNOVATIONANDRA
NDD/RANDDTAXCONCESSION/PAGES/RDTAXCONCESSION
.ASPX](http://www.usindustry.gov.au/innovationandrandd/randdtaxconcession/pages/rdtaxconcession.aspx)

Gary Hegedus
Productions



GARY HEGEDUS PRODUCTIONS

56 Smedley Road PARK ORCHARDS 3114 VIC AUSTRALIA

Tel: (03) 9876 2860 Mob: 0408 994 040

Skype: mr_film

e-mail gary@ghproductions.com.au

web www.ghproductions.com.au

YouTube www.youtube.com/user/Mrfilmvideos

Imagine you are bogged in
mud, sand or snow....

You need **X-tractor.**

Contact: Len Williams gyrolen@tpg.com.au

What is X-tractor?



An attachment
to fit to a tyre
when the
wheel has lost
traction.

Key features of X-tractor



N.B this is the prototype version , an improved model is in development which is even more compact.

- Quick, simple installation
- Convenient size
- Portable
- Suits variable tyre sizes

How does X-tractor work?

Part 1

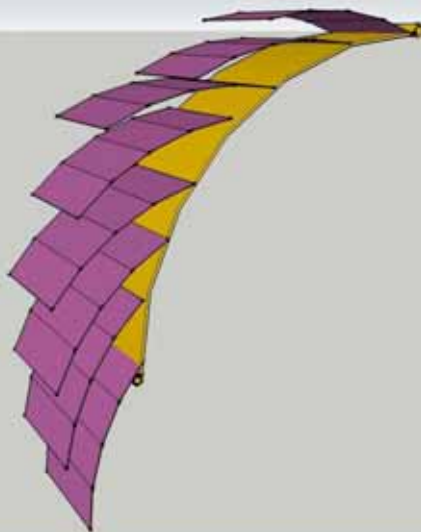

The flaps provide a soft, flexible, continuous pad with a larger surface area for the tyre.

How does X-tractor work?

Part 2

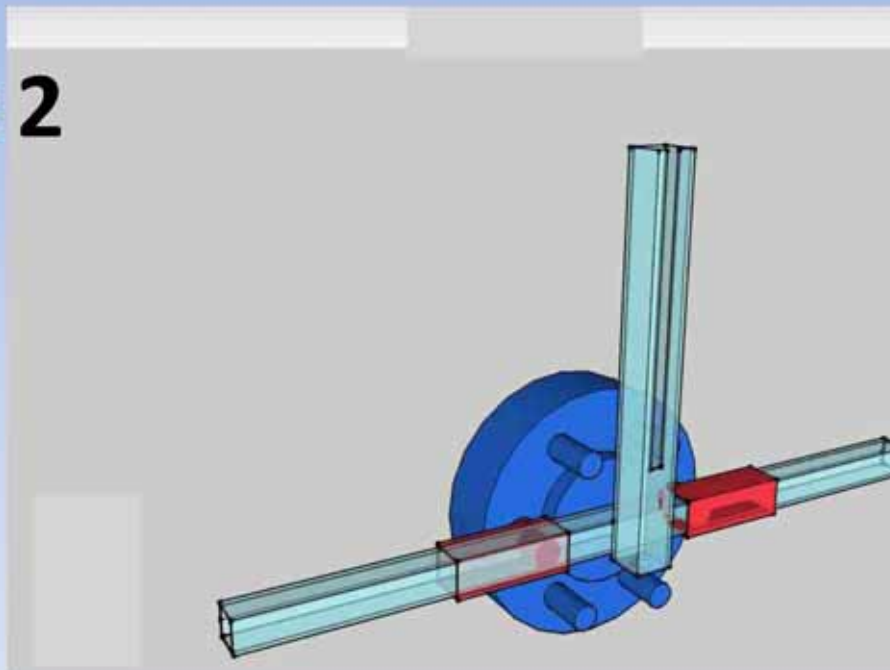

A strong steel frame holds the device in place on the wheel.

The complete X-tractor device

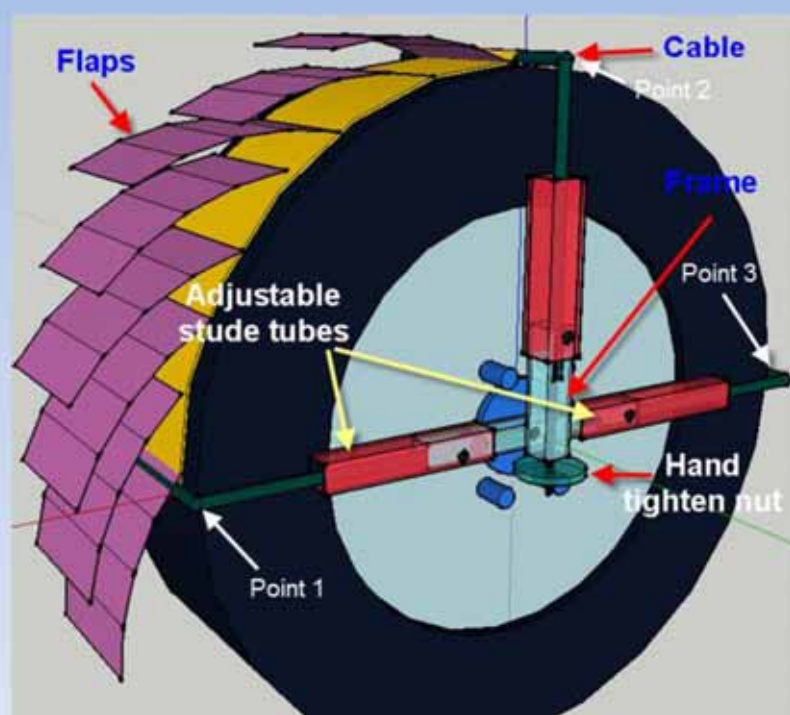

X-tractor in action

Extra traction when you need it!

